

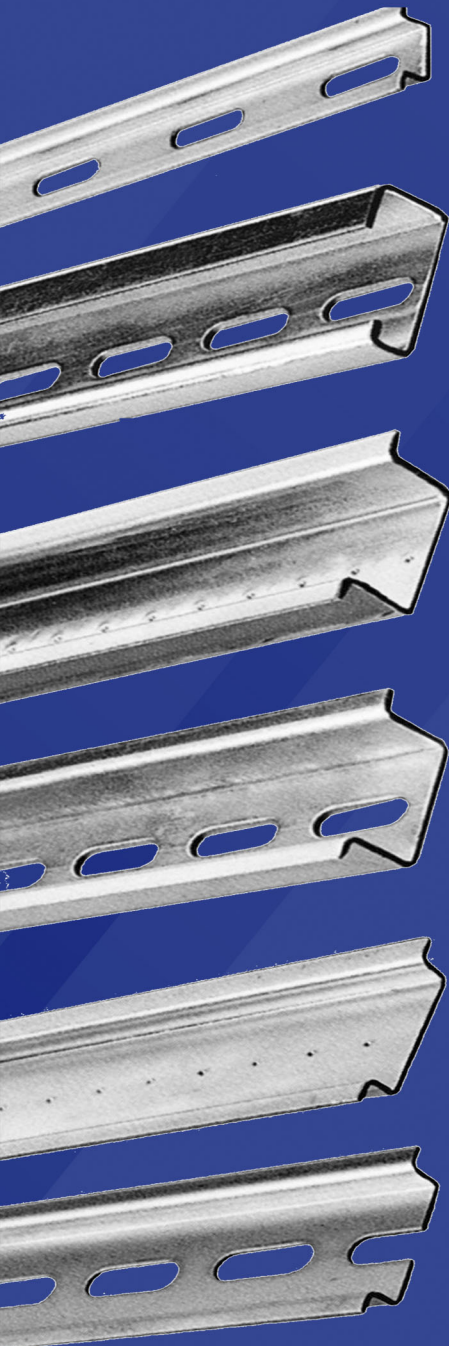

ELECTRICAL COMPONENTS

DIN Rail & Accessories

- 21 models of DIN Rail
- Standoff Brackets
- Hex Spacers ▪ Insulators
- DIN Rail Adaptors/Clips
- DIN Rail Tools



CE

DIN Rail

35x7.5mm Punched Mounting DIN Rail (TS35)

Standard DIN rail is made of cold rolled steel (RoHS compliant). Mounting holes in slotted models are punched after cold rolling in order to guarantee the dimensional tolerance and consistency in-hole sizing and spacing.

The standard supply length is 2m (approx. 78 3/4"), and some are also available in 1m (approx. 39 3/8") lengths. All rails can be cut and punched on demand.

Features and specifications:

- Construction as per the DIN EN 60715 Standard
- Dimension: 35x7.5mm
- Thickness: 1.0mm

35x7.5x1mm Punched Mounting DIN Rail (Order by Part No.)

Part No.	Model	Description	Length (m)	Differentiator	Weight per m (kg)	Standard Pack (m)
111.013	TS35/F6	Steel rail, punched 6.3x18mm pitch 25mm, zinc plated (RoHS compliant)	2m	Length - 2m	0.315	40m
111.020	TS35/F6m	Steel rail, punched 6.3x18mm pitch 25mm, zinc plated (RoHS compliant)	1m	Length - 1m	0.315	10m
111.037	TS35SS/F6	Stainless steel rail, punched 6.3x18mm, pitch 25mm	2m	Stainless steel	0.32	4m

Information subject to change without notice - All dimensions in mm except where noted

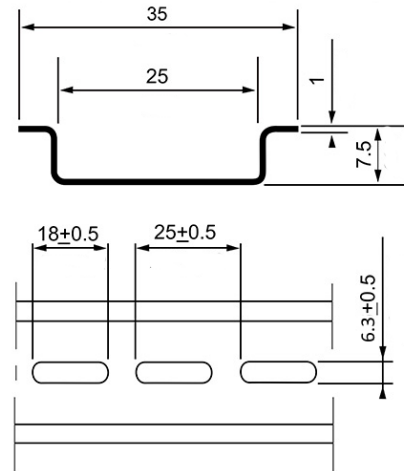
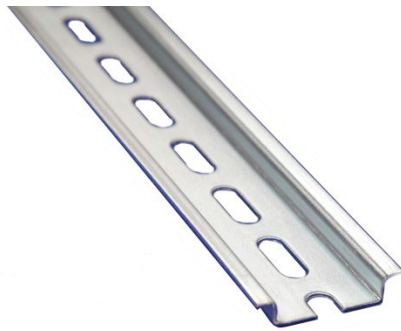



35x7.5mm Punched Mounting DIN Rail (Order by Part No.)

Part No.	Model	Description	Length (m)	Differentiator	Weight per m (kg)	Standard Pack (m)
111.023	TS35/F5	Steel rail, punched 5.1x25mm pitch 36 mm, zinc plated (RoHS compliant)	2m	Steel	0.32	40m
111.018	TS35P/F4	PVC rail, punched 3.1 x25mm, pitch 50mm, grey	1.83m	PVC	0.11	10m
111.033	TS35AL/F4	Aluminum rail, punched 4.5x25mm pitch 35 mm, thickness 1.5mm	1m	Aluminum	0.25	20m

Information subject to change without notice - All dimensions in mm except where noted



111.023



111.018

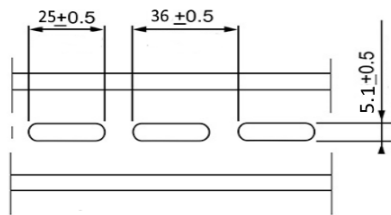
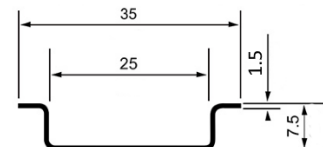
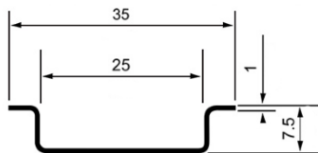
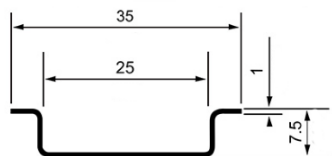

111.023

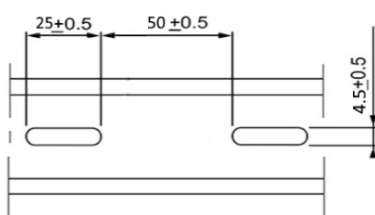

111.018

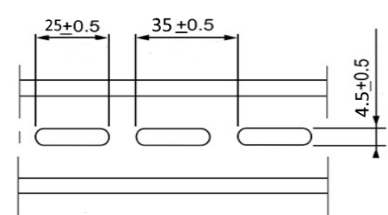

111.033



35x7.5x1mm Solid DIN Rail (Order by Part No.)

Part No.	Model	Description	Length (m)	Differentiator	Weight per m (kg)	Standard Pack (m)
111.010	TS35m	Symmetric steel rail, solid, zinc plated (RoHS compliant)	1m	Length - 1M	0.35	20m
111.011	TS35	Symmetric steel rail, solid, zinc plated (RoHS compliant)	2m	Length - 2M	0.35	40m
111.019	TS35 Cu	Symmetric copper rail, solid (RoHS compliant)	2m	Copper	0.4	2m
111.036	TS35AL	Symmetric aluminum rail, solid, thickness 1mm	2m	Aluminum	0.24	20m
111.038	TS35X F6	Symmetric stainless steel rail, solid, (RoHS compliant)	2m	Stainless steel	0.35	40m

Information subject to change without notice - All dimensions in mm except where noted

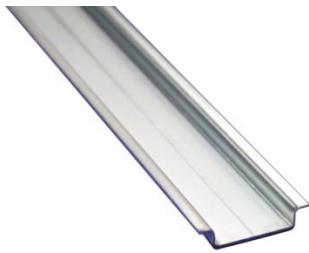

111.011

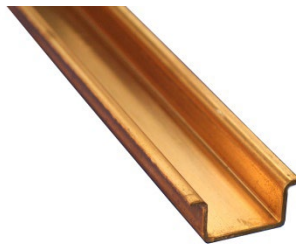

111.019

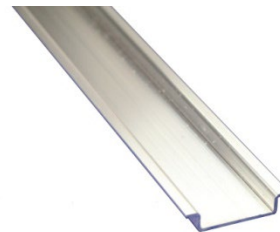

111.036

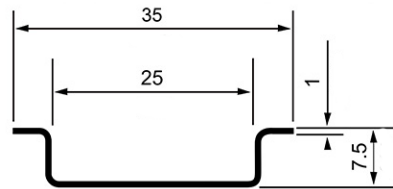

All DIN standard TS35 35x7.5mm ITC rails (except TS35AL) can be cut / punched with the following tools:

Part No. DIN Cutter	Equipped with:	Punching
510.300	M32 Die p/n 510.352	Yes
510.320	M32 Die p/n 510.352	Yes
510.501	-	Yes
510.520	-	No
510.601	-	Yes
510.801	-	No

35x15x1.5mm Heavy-Duty / High Mounting DIN Rail (TS35C)

- Construction as per Std. DIN EN 60715
- Dimension: 35x15mm
- Thickness: 1.5mm

DIN Standard 35mm (symmetric Heavy-Duty or “High”) Mounting Rail (Order by Part No.)

Part No.	Model	Description	Length (m)	Differentiator	Weight per m (kg)	Standard Pack (m)	Weight per pack (kg)
111.021	TS35C	Heavy-duty steel rail, solid, zinc plated (RoHS compliant)	2m	Solid	0.67	20m	13.40
111.025	TS35C/F6	Heavy-duty steel rail, punched 6.3 x 18mm pitch 25mm, zinc plated (RoHS compliant)	2m	Punched	0.62	20m	12.40
111.029	TS35CCu	Heavy-duty copper rail, solid	2m	Copper, solid	0.95	4m	3.80

Information subject to change without notice - All dimensions in mm except where noted



111.025

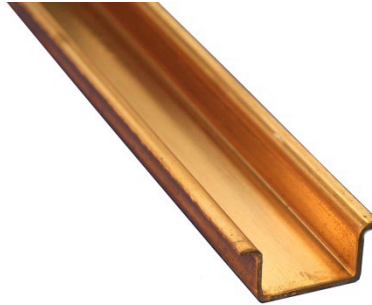

111.029

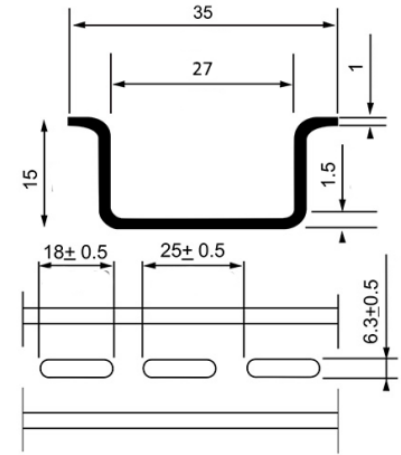

All DIN standard 35x15mm Heavy-Duty / High ITC rails can be cut / punched with the following tools:

Part No. DIN Cutter	Equipped with:	Punching
510.300	M33 Die p/n 510.353	Yes
510.320	M33 Die p/n 510.353	Yes
510.501	-	Yes
510.601	-	Yes



35x15x2.2mm Extra-Heavy-Duty Mounting DIN Rail (TS35I)

- Construction as per Std. DIN EN 60715
- Standard length is 3 metres
- Dimension: 35x15mm
- Thickness: 2.2mm

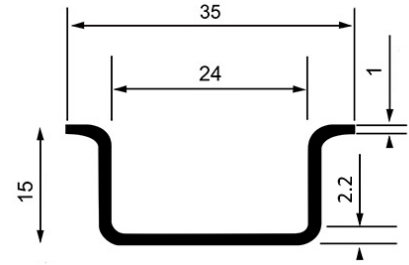

35x15x2.2mm Extra-Heavy-Duty Mounting DIN Rail (Order by Part No.)

Part No.	Model	Description	Length (m)	Weight per m (kg)	Standard Pack (m)	Weight per pack (kg)
111.031	TS35I	Symmetric extra-heavy-duty steel rail, solid, zinc plated	3m	0.95	6m	5.70

Information subject to change without notice - All dimensions in mm except where noted

Can be cut with the following tool + die combination:

Part No. DIN Cutter	Equipped with:	Punching
510.320	M34 Die p/n 510.354	No

35mm “Raised” Aluminum Mounting DIN Rail (TS35H)

Compatible with Std. DIN EN 60715 (top section of rail only)

This rail allows assembling all the panel components at a level which is higher than the wiring ducts. The 50mm high continuous support is punched with 22.5mm diameter holes, to provide greater accessibility and ease of wiring. Wire protecting grommets and plastic plugs are available.

- Dimensions: 35x7.5mm on 50mm raised base
- Thickness: 1.5mm

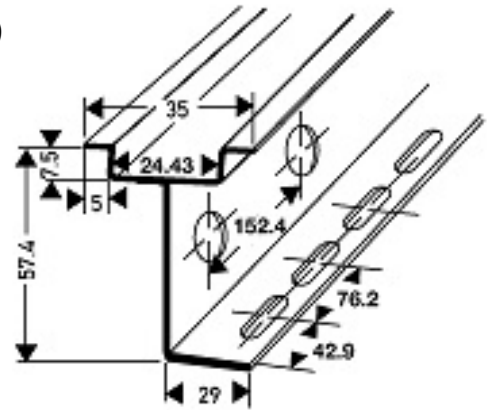

DIN Compatible 35mm (Raised) Mounting DIN Rail (Order by Part No.)

Part No.	Model	Description	Length (m)	Weight per m (kg)	Standard Pack (m)	Weight per pack (kg)
111.048	TS35HSA	Raised Symmetric Aluminum rail, solid, (RoHS compliant)	1m	0.95	2 m	1.90

Information subject to change without notice - All dimensions in mm except where noted

Accessories for DIN Compatible 35mm (Raised) Mounting DIN Rail

Part No.	Description
111.154	22.5mm plastic grommet for wire protection, black
111.164	22.5mm plastic plug, black

Can be cut with the following tool:

Part No. DIN Cutter	Punching
510.520	No



32mm Asymmetric Mounting DIN Rail (TS32)

- Construction as per Std. DIN 46277-1 and EN 50035
- Dimension: 32x15mm
- Thickness: 1.5mm

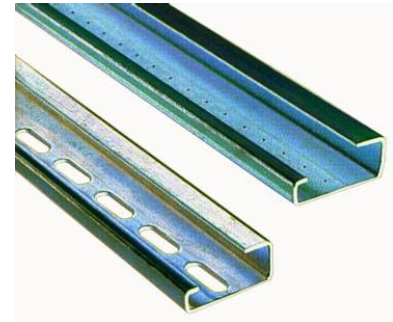
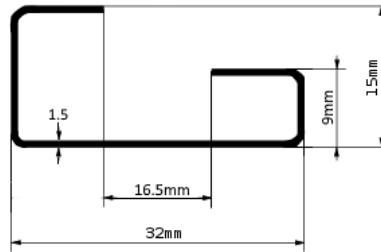

DIN Standard 32mm (asymmetric) Mounting DIN Rail (Order by Part No.)

Part No.	Model	Description	Length (m)	Differentiator	Weight per m (kg)	Standard Pack (m)	Weight per pack (kg)
111.001	TS32	Asymmetric Steel rail, solid, zinc plated (RoHS compliant)	2m	solid	0.74	20m	14.80
111.005	TS32/F6	Asymmetric Steel rail, punched 6.3x18mm pitch 25mm, zinc plated (RoHS compliant)	2m	Punched	0.68	20m	13.90

Information subject to change without notice - All dimensions in mm except where noted

Can be cut / punched with the following tools:

Part No. DIN Cutter	Equipped with:	Punching
510.300	M31 Die p/n 510.351	Yes
510.320	M31 Die p/n 510.351	Yes
510.501	-	Yes
510.601	-	Yes

75x26x3mm Extra-Heavy-Duty “LARGE” Mounting DIN Rail (TS75)

The extra heavy-duty DIN (profile in cold-rolled steel, solid and galvanized, measuring 75x26 mm is ideal for mounting of heavy devices (contactors, breakers, etc.) *inside electrical panels and switchgear*. Cutting is done with a hacksaw or with a rotary/band electric saw.

- Construction as per Std. CENELEC EN 50023
- Dimensions: 75x26mm
- Thickness: 3.0mm
- Material: Cold rolled steel
- Plating: Zinc, with yellow bi-chromate finish. RoHS compliant finish upon request

75X26X3mm Extra-Heavy-Duty “LARGE” Mounting DIN Rail (Order by Part No.)

Part No.	Model	Description	Length (m)	Weight per m (kg)	Standard Pack (m)	Weight per pack (kg)
111.075	TS75	Symmetric extra-heavy-duty 75mm steel rail, solid, zinc plated	2m	1.95	2 m	3.9

Information subject to change without notice - All dimensions in mm except where noted

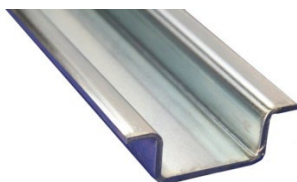

111.075

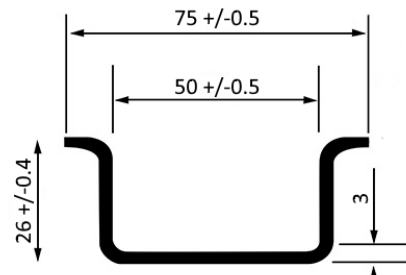



15x5.5x1mm “Miniature” Mounting DIN Rail (TS15)

- Construction as per Std. DIN 46277/2 and EN 50045
- Designed to mount components equipped with miniature 15 mm foot
Dimensions: 15x5mm
- Thickness: 1.0mm

15x5.5X1mm “Miniature” Mounting DIN Rail (Order by Part No.)

Part No.	Model	Description	Length (m)	Differentiator	Weight per m (kg)	Standard Pack (m)	Weight per pack (kg)
111.015	TS15/F4	Miniature steel rail, punched 4.2x12.2mm pitch 20mm, zinc plated (RoHS compliant)	2m	Punched	0.20	20m	4.00
111.016	TS15	Miniature steel rail, solid, zinc plated (RoHS compliant)	2m	Solid	0.21	20m	4.20

Information subject to change without notice - All dimensions in mm

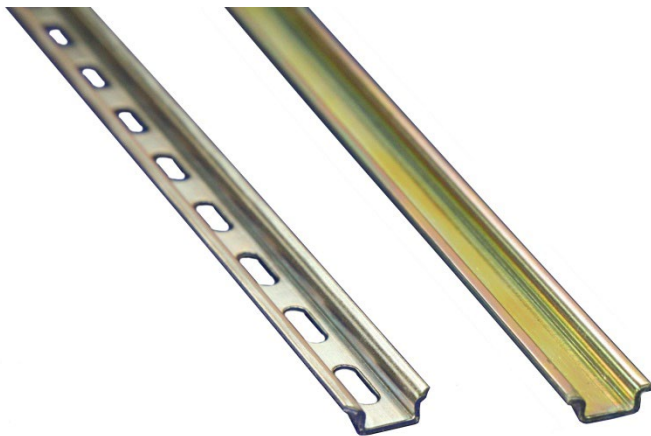

111.015

111.016

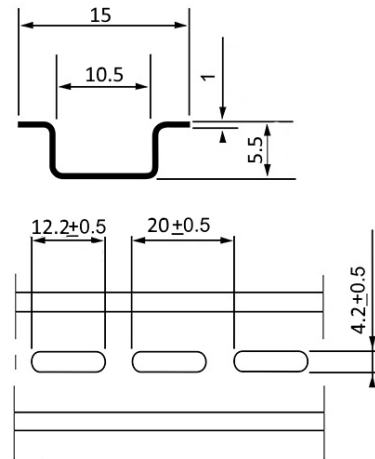

Can be cut with the following DIN Cutting tools:

Part No. DIN Cutter	Equipped with:	Punching
510.300	M35 Die p/n 510.355	Yes
510.320	M35 Die p/n 510.355	Yes
510.501	-	No
510.520	-	No
510.601	-	No
510.811	-	No



Accessories for DIN Rail

Insulators

Low-voltage standoff insulators from ITC are made of polyester resin, reinforced with fiberglass to ensure high resistance to electrical and mechanical stress. With female threaded brass inserts at both ends, these insulators feature a hexagonal central band to facilitate application.

- Colour: dark red
- Operating temperature: -40 to +130 °C
- Water absorption (ASTM D-570) = 0.20%

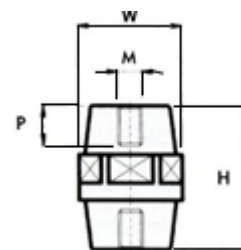

Standoff Insulators (Order by Part No.)

Part No.	Height H (mm)	Wrenching flats W (mm)	Threaded inserts M x P	Surface flash-over voltage	Operating voltage AC (V)	Pack
100.320	20	17	M6 x 5mm	3kV	400	10
100.325	25	19	M6 x 7mm	5kV	600	10
100.330	30	32	M6 x 8mm	7kV	600	10
100.340	40	41	M6 x 8mm	10kV	1000	10
100.342	40	46	M8 x 10mm	10kV	1000	10
100.350	50	36	M6 x 15mm	15kV	2000	10
100.351	50	36	M8 x 10mm	15kV	2000	10
100.360	63	41	M6 x 15mm	20kV	3000	10
100.361	60	55	M10 x 15mm	20kV	3000	10
100.362	63	41	M10 x 15mm	20kV	3000	10
100.375	75	50	M8 x 25mm	20kV	5000	10
100.401	100	65	M10 x 25mm	25kV	8000	10

Note: voltage characteristics are according to EEC Standards. Information subject to change without notice - All dimensions in mm.

Steel Spacers

Steel spacers (or standoffs) can be used as an alternative to brackets, as they greatly reduce the panel space required, to stand-off DIN rail or components within an electrical panel.

- Material: Steel, zinc plated (RoHS compliant)
- Threads: metric M6, male (M) and female (F)

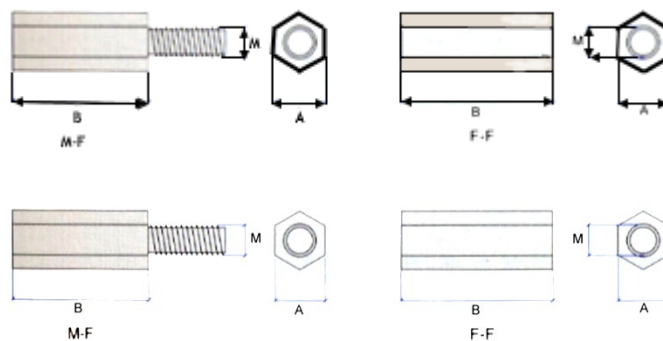

Steel Spacers (Standoffs) (Order by Part No.)

Part No.	Description	Height B	Wrench flat A	Pack
100.215	M-F steel standoff, 15mm (~0.6")	15mm	10mm	10
100.225	M-F steel standoff, 25mm (~1")	25mm	10mm	10
100.240	M-F steel standoff, 40mm (~1 1/2")	40mm	10mm	10
100.250	M-F steel standoff, 50mm (~2")	50mm	10mm	10
100.299	M-F steel standoff, 100mm (~4")	100mm	10mm	10

F-F models upon request - Information subject to change without notice - All dimensions in mm

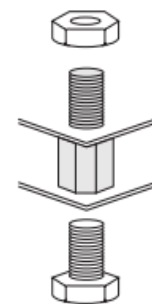

Accessories for Insulators and Steel Spacers (Order by Part No.)

Part No.	Description	Pack
100.005	M5 screw, flat head; l= 12mm	100
100.006	M6 screw, flat head; l= 12mm	100
100.008	M6 nut, steel	100

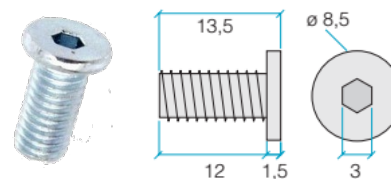



Support Brackets

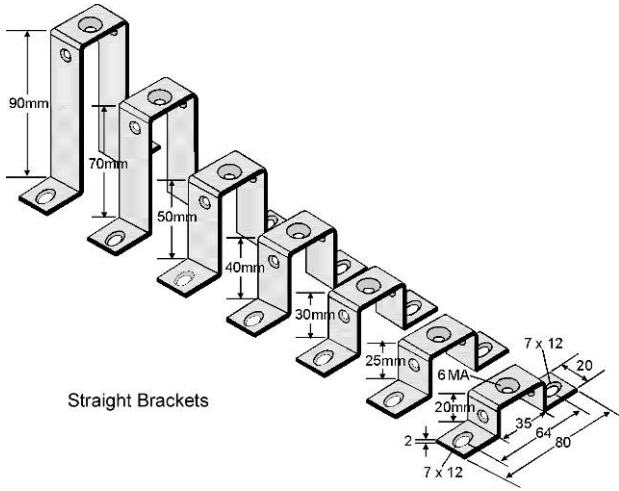

Straight Brackets

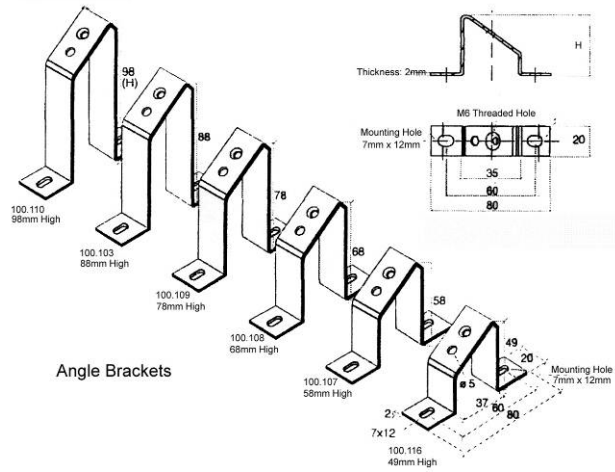

Angle Brackets

Steel brackets are used to stand-off DIN rail or components within an electrical panel.

- Made of steel, zinc plated and passivated (RoHS compatible)
- Extremely resistant to corrosion
- Threaded holes are metric M5 or M6 as indicated
- Mounting holes are 7x12mm for easy application

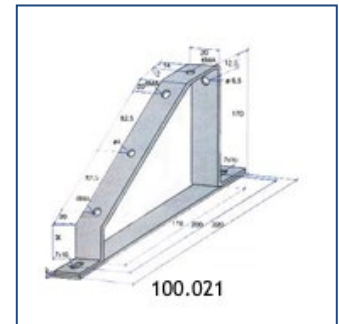
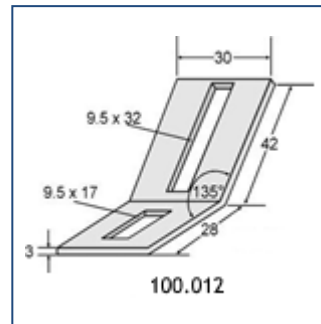
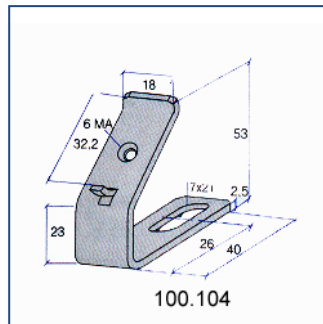
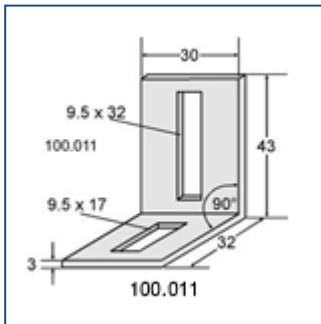

Support Brackets & Accessories (Order by Part No.)

Part No.	Description	Width x height (mm)	Pack
100.011	Angle bracket, 90 degrees, slotted	30 x 43	10
100.012	Angle bracket, approx. 135 degrees, slotted	30 x 40	10
100.021	Heavy-duty angle bracket 170mm, 2 M6 threaded holes	20 x 170	1
100.104	Slanted "C" bracket, approx. 45 degrees, height 53 mm thread M6	18 x 53	10
100.105	Angle bracket, approx. 45 degrees, height 45mm thread M5	20 x 45	10
100.107	Angle bracket, approx. 45 degrees, height 58mm thread M6	20 x 58	20
100.108	Angle bracket, approx. 45 degrees, height 68mm thread M6	20 x 68	20
100.109	Angle bracket, approx. 45 degrees, height 78 mm thread M6	20 x 78	20
100.110	Angle bracket, approx. 45 degrees, height 98mm thread M6	20 x 98	20
100.115	Angle bracket, approx. 45 degrees, height 49mm thread M5	20 x 49	10
100.116	Angle bracket, approx. 45 degrees, height 49mm thread M6	20 x 49	10
100.201	Straight bracket, height 20mm thread M6	20 x 20	20
100.251	Straight bracket, height 25mm thread M6	20 x 25	20
100.301	Straight bracket, height 30mm thread M6	20 x 30	10
100.441	Straight bracket, height 40mm thread M6	20 x 40	10
100.501	Straight bracket, height 50mm thread M6	20 x 50	10
100.706	Straight bracket, height 70mm thread M6	20 x 70	10
100.904	Straight bracket, height 90mm thread M6	20 x 90	10

Information subject to change without notice - All dimensions in mm

Accessories for Standoff Insulators & Support Brackets

Part No.	Description	Pack
100.005	M5 screw, flat head l= 12mm	100.115
100.006	M6 screw, flat head l= 12mm	
100.008	M6 nut, steel	

Clips/Adapters for Mounting on Din Rail

Use these useful accessories to DIN Rail mount various types of components which are not equipped with a DIN foot.

Clips & Adapters for DIN Rail (Order by Part No.)

Part No.	Description	Mounting holes	Weight (g)	Pack
100.144	Metal clip for TS35 Rail - steel	1 x M4	5	10
100.145	Metal clip for asymmetric TS32 Rail - steel	1 x M5	5	10
100.146	Metal clip for asymmetric TS32 Rail - steel	1 x M4	5	10
100.135	Plastic insert for asymmetric TS32 Rail - Black	1 x M3 + 1 x M5	4	10
100.136	Plastic insert for asymmetric TS32 Rail - White	1 x M4 + 1 x M6	4	10
100.031	Heavy-duty mounting base for TS35 (R)- Steel	2 x M6	70	1
100.032	Heavy-duty mounting base for TS35 (L)- Steel	2 x M6	70	1

Information subject to change without notice - All dimensions in mm



100.144



100.135

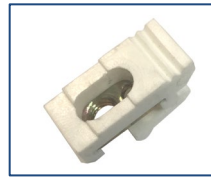

100.136

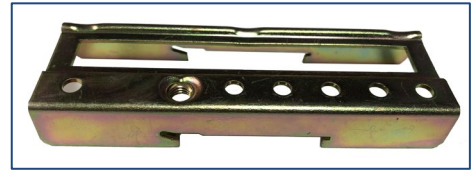

100.032

Special Mounting Brackets

These handy accessories are designed to mount various types of components such as control devices and instruments, inside a control panel. Item 100.042 is a special support with a $\Phi 22.5\text{mm}$ hole. When mounted behind a control device of the same size (Pushbutton, pilot light), and it allows mounting by means of one or more 6mm screws, a variety of devices such as wire clamps, wire ducts, auxiliary transformers, cable ties, etc., on the same 22.5mm hole where a control device is mounted, without the need to drill another hole in the panel.

Special Brackets (Order by Part No.)

Part No.	Description	Dimensions (mm)	Weight (g)	Pack
100.041	Steel support for 22.5mm devices	H=90 W=35 D=76	85	1
100.042	Support bracket for extra components, mounts on any 22.5mm diameter hole	H=7 W=30 D=90	45	1
100.046	Adapter kit for Steel support, from 22.5 to 10mm	Ext. Dia. 30mm	10	1

Information subject to change without notice - All dimensions in mm

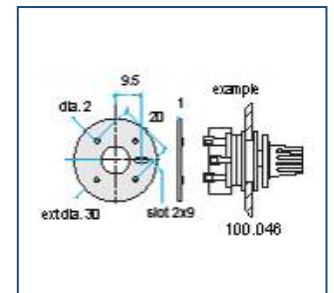
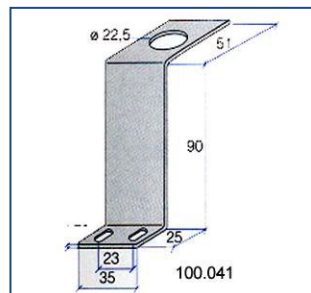
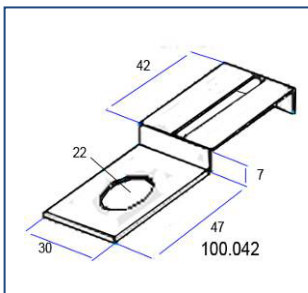

DIN-Rail Mounted Utility Box

DIN-Rail Utility Boxes are a convenient DIN-rail mounted enclosures, designed for handy storage of small parts inside a panel or electric cabinet. They can be used to store, in proximity to the equipment for which the parts are intended, spare parts and accessories such as miniature lamp bulbs, fuses, keys, adhesive labels, screws and washers, crimp terminal and ferrules, batteries...

- **Easy installation:** equipped with a snap foot for 35mm DIN rail, they can be easily installed or removed with the aid of a small screwdriver. The 111.200 version can be mounted on vertical as well as horizontal DIN rail
- **Compact:** small enough (45x54x75mm ~ 2.25x1.75x3”) to be mounted alongside most components on DIN Rail (terminal blocks, PLCs, fuse holders) without impeding access or operation, yet capable of storing a surprising amount of frequently needed small spares
- **Materials:** Polystyrene (blue/white, green/white); flame-retardant

DIN Rail Utility Boxes (Order by Part No.)

Part No.	Description	Model	Std. Package
111.200	DIN Utility Mounted Box (DUMB box, blue/white)	-	10
SP799-103	BordCase (green/white)	BC-G	15

Information subject to change without notice

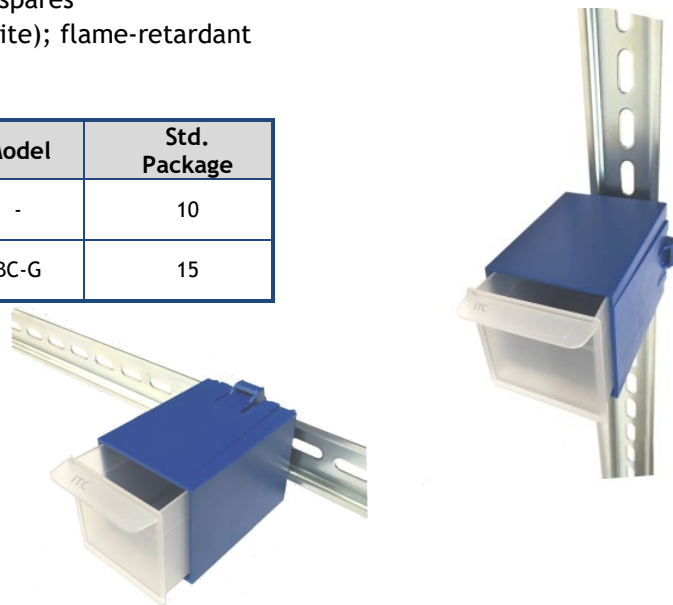

The RoHS Directive and ITC DIN Rails



The Directive issued by The European Union N. 2002/95/EC, commonly known as “RoHS Directive” determines that, effective July 1st, 2006, all electrical and electronic equipment marketed in the member States, must not contain certain hazardous substances, among which is Cr₆, or Hexavalent Chromium. This substance has been extensively used in the past to protect steel products against corrosion, giving them the typical “yellow finish”.

After a series of lengthy researches and tests, ITC’s DIN rail produced after 2006 have been treated exclusively with a process which guarantees both compatibility with the RoHS directive and superior resistance to corrosion. This has been tested according to Standards ISO 9227NS, DIN 50021 SS, and AST B 117/97, by submitting the products to Salt Spray Tests. The white passivation applied to ITC’s DIN Rails has been proven effective up to 96 hours of such tests, well in excess of the values imposed by the different Standards.

For the same reason, ITC has long discontinued DIN rails manufactured with steel protected with the system known as “Sendzimir” (Zinc galvanizing process before cold rolling) because such more economical treatment, although compatible with the RoHS directive, provides Salt Spray Test resistance much inferior to the passivation now in use for ITC’s DIN Rails.

DIN Rail installations

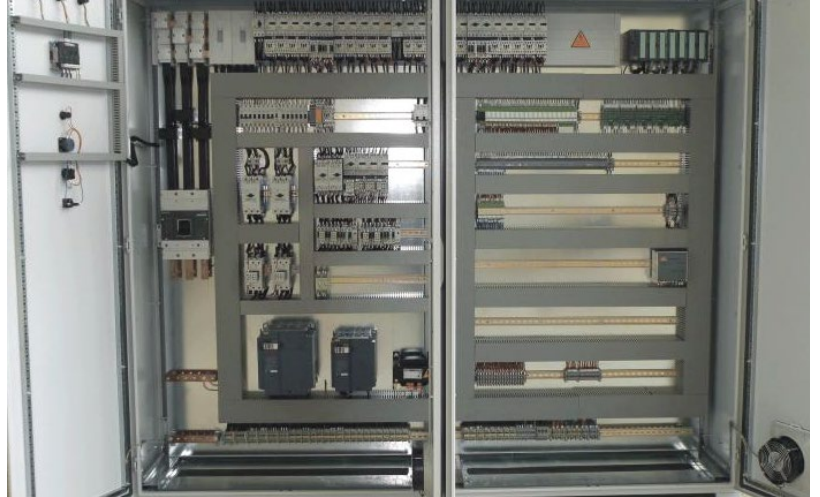

DIN Rail Cutting and Punching Tools

ITC offers 10 different DIN rail cutting and punching tools for all possible DIN rail processing requirements, as well as custom tools. From compact and portable Handy-Cut tools to manual bench mount tools and pneumatic tools, ITC covers all DIN rail processing options.

Refer to the convenient selection guide on the opposite page.

Handy-Cut Series:

The portable Handy-Cut series are compact, fully portable tools (weight 2.5-4.6 kg / 6-10 lbs) which cleanly cut DIN rails. With their two handles, there is no need to bench-mount these tools - cutting requires minimal effort. These tools are designed and priced for the small panel builder and contractor.

DRCP:

The DRCP tool provides excellent value in one single, bench-mounted machine that cuts the five types of common DIN rails and punches 4 types of DIN rails, without changing dies.

PSG Series:

The PSG series provide in one single, bench-mounted machine, the most efficient solution for cutting (and punching - PSG 5+ models) all four types of common DIN rails, without changing dies.

GH3 series:

GH3 series tools are extremely sturdy, professional bench mounted DIN cutters / punchers. They are available in manual or pneumatic versions. These machines provide the fastest operation available amongst the models offered by ITC. All models can cut and punch selected rails in one operation only.



Warranty information

All ITC DIN Rail cutters are covered by a limited warranty of 1 year on all manufacturer defects.

DIN-Rail Cutting Tools Selection Guide

Cutter	TS35 35x7.5x1*	TS35C 35x15x1.5	TS32 32x15x1.5	TS15 15x5x1	Other Profiles	Punches	Operation	Other
510.501 	✓	✓	✓	✓	Cu bars 10x3mm	12X6.4	manual	
510.510 	✓	✓			Cu bars 10x3mm		manual	
510.520 	✓	✓			high rise aluminum rail		manual	
510.571 	✓	✓	✓	✓	Cu bars 10x3mm	12X6.4	hydraulic	with hydraulic cylinder
510.801 	✓						manual	portable
510.821 		✓					manual	portable
510.811 				✓			manual	portable
510.601 	✓	✓	✓	✓		8.8x5 either direction	manual	
510.300 	✓	✓	✓	✓	TS35I C 30x15x1.5 C 20x14x1.5	13x6.5 custom	manual	
510.320 	✓	✓	✓	✓	TS35I C 30x15x1.5 C 20x14x1.5 Schneider AM1 ED200 & ED201 ALU DIN	13x6.5 custom	pneumatic	

* not aluminum 111.033

Information subject to change without notice - All dimensions in mm except where noted



ELECTRICAL COMPONENTS

416.663.7223
www.itcproducts.com
 50 Mural St Unit 8
 Richmond Hill, ON L4B 1E4



DIN Rail



DIN Rail Accessories



Hinged Enclosures



Thermal Management



PANEL Lighting



Multipole Connectors



Compact IP68 Connectors



Terminal Blocks



Terminal Strips

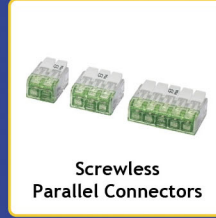

Screwless Parallel Connectors



22.5mm Pushbuttons



LED Indicators



Control Stations



Limit Switches



Micro Limit Switches



Safety Switches



Foot Switches

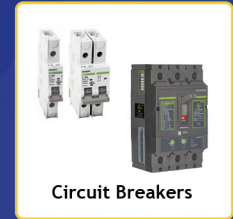

Circuit Breakers



IEC Contactors

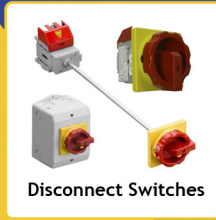

Disconnect Switches



Midget and CC Fuse Holders



Tower Lights



Power Continuity



Ferrules



Colour Coded Lugs



Crimp Terminals



Termination Kits



Cable Glands

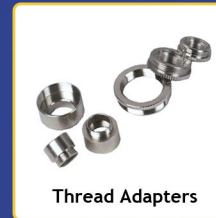

Thread Adapters



Cable Entry Systems



Wire Management



DIN Rail Cutters



Assembly Tables



Cutting & Stripping



Crimping Tools



Hole Cutting & Punching Tools

SOME OF OUR MANUFACTURING PARTNERS

